

## LIGHT DUTY LINE VAC™ INSTALLATION & MAINTENANCE

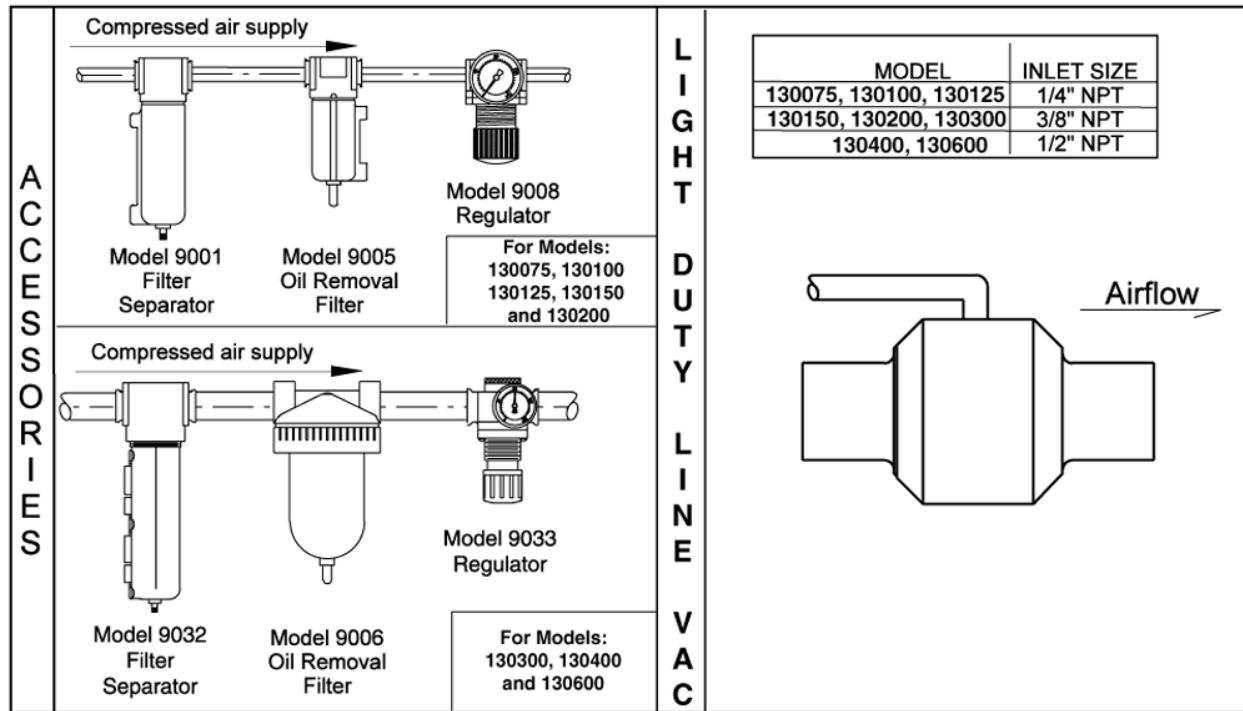

### COMPRESSED AIR LINE SIZES

For Light Duty Line Vac Models 130075 - 130200 use 1/4" pipe or 3/8" hose for runs up to 25' (7.6m) long. For runs up to 50' (15.2m), use 3/8" pipe or 1/2" hose and for runs over 50' (15.2m), use 1/2" pipe or larger. For Light Duty Line Vac Models 130300 - 130600, use 1/2" pipe or larger. Do not use restrictive fittings or undersized lines that can "starve" the Light Duty Line Vac by causing excessive line pressure drop.

### COMPRESSED AIR SUPPLY

With proper filtration and separation of dirt, moisture and oil from the compressed air supply, the Light Duty Line Vac will operate for years with no maintenance required.

Use a 10 micron or smaller filter separator on the compressed air supply (Model 9001 Automatic Drain Filter Separator for Models 130075 - 130200, Model 9032 Automatic Drain Filter Separator for Models 130300 - 130600).

To prevent problems associated with oil, use an oil removal filter (Model 9005 Oil Removal Filter for Models 130075 - 130200, Model 9006 Oil Removal Filter for Models 130300 - 130600). The oil removal filter should be used downstream from the automatic drain filter separator. Filters should be used close to each Light Duty Line Vac, within 10 to 15' (3 to 4.6m) is best.

Light Duty Line Vac is designed to use normal shop air supplies up to 100 PSIG (6.9 BAR, 689 kPa). For infinite control of flow and force, pressure may be regulated (Model 9008 Pressure Regulator for Models 130075 - 130200, Model 9033 Pressure Regulator for Models 130300 - 130600). Maximum pressure is 250 PSIG (17.2 BAR, 1.72 MPa).

If air preparation units other than EXAIR models are being used, please note the following:

- **PRESSURE REGULATORS** – Must be pressure relieving and rated for a supply pressure of 250 PSIG (17.2 BAR, 1.72 MPa). Suggested operating pressure is 5-125 PSIG (0.3-8.6 BAR, 34-862 kPa). For models 2" (51mm) and under, flow should be minimum 50 SCFM (1416 SLPM). For models over 2" (51mm), flow should be minimum 90 SCFM (2549 SLPM).
- **AUTO DRAIN FILTER SEPARATORS** – Must be rated for a supply pressure of 250 PSIG (17.2 BAR, 1.72 MPa) and have 25 micron filtration. For models 2" (51mm) and under, flow should be minimum 50 SCFM (1416 SLPM). For models over 2" (51mm), flow should be minimum 90 SCFM (2549 SLPM).

- OIL REMOVAL FILTERS – Must be rated for a supply pressure of 250 PSIG (17.2 BAR, 1.72 MPa) and have 0.03 micron filtration. For models 2" (51mm) and under, flow should be minimum 50 SCFM (1416 SLPM). For models over 2" (51mm), flow should be minimum 90 SCFM (2549 SLPM).

### **USING LIGHT DUTY LINE VAC**

In most cases, the Light Duty Line Vac will be supported by the compressed air supply pipe. Mounting brackets are not available for the Light Duty Line Vac.

Light Duty Line Vac units are made in various sizes to be used with standard hose or tube. They perform best when mounted at the suction point, however, a hose or tube can be attached to either or both ends of the unit. Hose or tube should be straight when possible and bends minimized to reduce back pressure.

**WARNING: Do not use with any material that can create an explosive mixture**

### **HOW LIGHT DUTY LINE VAC WORKS**

Compressed air flows through the inlet (1) into an annular plenum chamber (2). It is then injected into the throat through directed nozzles (3). These jets of air create a vacuum at the intake (4) which draws material in and accelerates it through the unit (5) at long vertical or horizontal distances.

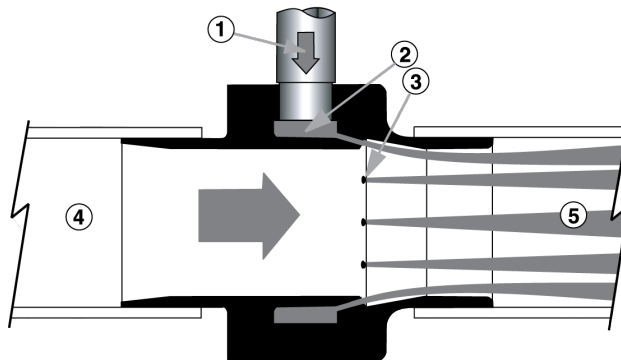

### **ADJUSTING THE LIGHT DUTY LINE VAC**

The flow generators have a series of holes that convey the material. Conveying speed can be controlled with a pressure regulator. For greater speeds and conveying distances, the generator holes can be made larger with a drill (disassembly required - see "Cleaning"). It is recommended that all hole diameters be increased in 1/64" (.40mm) intervals and tested.

### **TROUBLESHOOTING & MAINTENANCE**

**If There Is A Reduction In Flow Or Vacuum From The Light Duty Line Vac**, check the pressure by installing a gauge at the compressed air inlet of the Light Duty Line Vac. Large pressure drops are possible due to undersized lines, restrictive fittings and clogged filter elements.

**For replacement or repair filter and regulator parts, contact EXAIR at 1-800-903-9247 or [techhelp@exair.com](mailto:techhelp@exair.com). Call (513) 671-3322 for outside the US and Canada.**

### **CLEANING**

If contaminants have clogged the Light Duty Line Vac, disassemble the unit by holding the exhaust end firm while turning the intake end counter-clockwise (make sure the compressed air is off). Inspect each part for dirt contamination and a possible oil film on the flow generator. Clean each part and reassemble. The Light Duty Line Vac consists of a body, a threaded cap with attached flow generator and two O-rings.

Occasionally, there is a build up which occurs in the throat of the Light Duty Line Vac as a result of vapors in the atmosphere. Clean the surface with a solvent and a clean rag. To prevent contaminants from getting pushed back into the generator holes, perform this procedure with a small amount of compressed air passing through the Light Duty Line Vac.

If you have any questions or problems, please contact:

#### **YOUR INFO HERE:**

Company Name

Telephone

FAX:

Email:

Website: