

GEN4 SUPER ION AIR WIPE™ INSTALLATION & MAINTENANCE

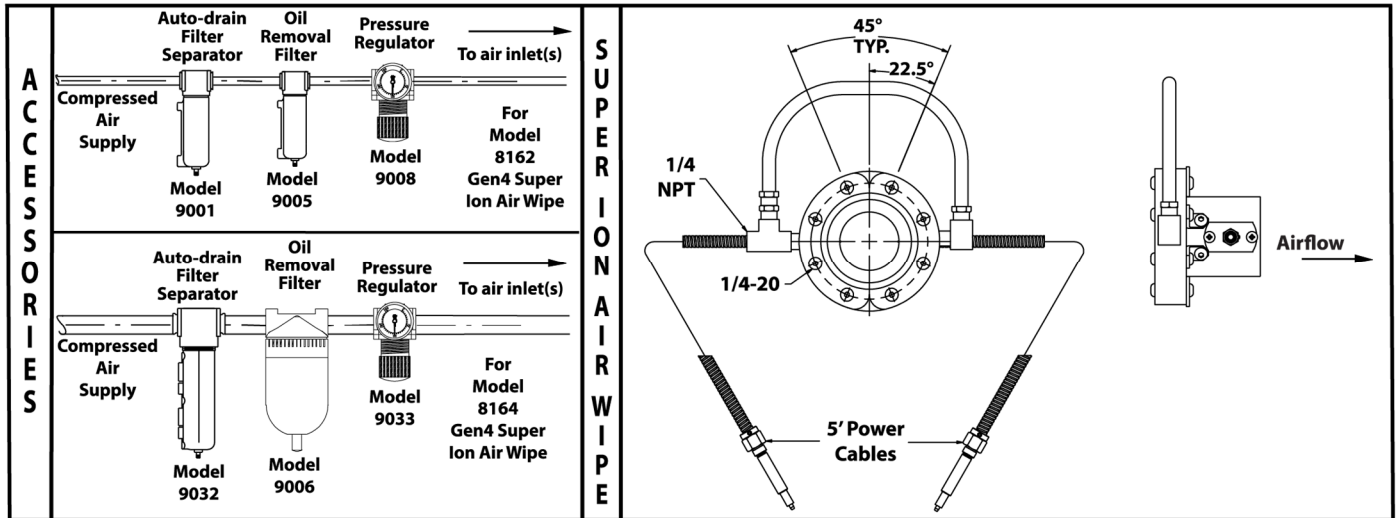

COMPRESSED AIR LINE SIZES

Compressed air lines should be sized to hold pressure drops to a minimum. Do not use restrictive fittings or undersized lines that can starve the Gen4 Super Ion Air Wipe by causing excessive line pressure drop.

GEN4 SUPER ION AIR WIPE RECOMMENDED INFEED PIPE SIZES				
Gen4 Super Ion Air Wipe Size	Model Numbers	Infeed Pipe Size		
		Length of Run		
		10' (3m)	50' (15.2m)	100' (30.5m)
2" (51mm)	8162	3/8"	1/2"	3/4"
4" (102mm)	8164	1/2"	3/4"	1"

If hose is used instead of pipe, use the next larger size for proper airflow (1/4 pipe = 3/8 hose).

GEN4 SUPER ION AIR WIPE RECOMMENDED FILTERS AND REGULATORS			
Gen4 Super Ion Air Wipe Model #	Filter-Separator Model #	Oil Removal Filter Model #	Pressure Regulator Model #
8162	9001	9005	9008
8164	9032	9006	9033

See the chart above for proper filter and regulator recommendations for each Gen4 Super Ion Air Wipe model.

COMPRESSED AIR SUPPLY

With proper filtration and separation of dirt, moisture and oil from the compressed air supply, the Gen4 Super Ion Air Wipe will operate for years with no maintenance required. Use a 10 micron or smaller filter separator on the compressed air supply.

To prevent problems associated with oil, use an oil removal filter. The Oil Removal Filter should be used downstream from the Automatic Drain Filter Separator. Filters should be used close to each Gen4 Super Ion Air Wipe, within 10' to 15' (3 to 4.6m) is best.

The Gen4 Super Ion Air Wipe is designed to use normal shop air supplies up to 100 PSIG (6.9 BAR). For infinite control of flow and force, pressure may be regulated.

USING THE GEN4 SUPER ION AIR WIPE

Screw the bayonet connector of the high voltage power cable into the power supply. Make sure the hex swivel fitting is fully seated against the power supply terminal. Upon installation, the ionizer cable should be isolated from grounded metal surfaces by using non-conductive stand-offs/wire ties by at least 1" of air gap. Alternatively, the ionizer cable can be shielded in plastic conduit with dielectric strength equivalent to at least 1" of air (approximately 75kV/inch).

The Gen4 Super Ion Air Wipe is supplied with coupling brackets for each half. One bracket is designed to remain stationary while the other has a notch for latching the two halves together.

All models include stainless steel screws and shims. There is a 1/4 NPT female inlet on each half of the Super Air Wipe. Gen4 Super Ion Air Wipes include a brass tee that supplies one half directly and a stainless steel wire braided coupling hose to supply the other half.

The air flows from the side with the screw heads to the opposite side. It is best to position the Gen4 Super Ion Air Wipe so the material running through the center is evenly spaced from all surfaces.

For mounting, there are tapped holes on the back of the Gen4 Super Ion Air Wipe. It can also be held in place with rigid pipe. The Gen4 Super Ion Air Wipe is supplied with a .002" (.05mm) thick shim in each half. If additional hard-hitting force is required, additional shims are available.

GEN4 SUPER ION AIR WIPE SHIM SET

Force and flow from the Super Air Wipe may be easily increased by adding shims to open the air gap. The Gen4 Super Ion Air Wipe is supplied with a .002" (.05mm) thick shim installed. It sets the air slot to a .002" (.05mm) opening. To increase the air gap, use a shim set (included with the Gen4 Super Ion Air Wipe Kit). The shim set includes (2) .002 (.05mm) thick stainless steel shims. By changing and stacking them, gaps may be set from .002" to .004" (.05mm to .10mm). Individual shims are available.

To change shims, remove the assembly bolts. Inspect the Gen4 Super Ion Air Wipe and shim(s) to assure no dust, dirt or chips are on the mating surfaces or in the plenum chamber. Replace or add a shim(s), and retighten bolts to 7.5 ft. lbs. Note that mating parts (body and cap) do not align flush. The air opening cannot be dead ended, which meets OSHA requirements.

ELECTRICAL SUPPLY

The Model 7960 Power Supply (two outlet) and Model 7961 Power Supply (four outlet) require a 115V or 230V, 50/60Hz source. For proper operation, the Gen4 Super Ion Air Wipe and power supply must be properly grounded. If the unit is not grounded, the Gen4 Super Ion Air Wipe will produce a shock and will not function properly. The hex swivel fitting on the Gen4 Super Ion Air Wipe must be fully seated against the power supply terminal.

TROUBLESHOOTING AND MAINTENANCE

If There Is A Reduction In Flow Or Force From The Gen4 Super Ion Air Wipe, check the pressure by installing a gauge at the compressed air inlet. Large pressure drops are possible due to undersized lines, restrictive fittings and clogged filter elements.

For replacement or repair filter and regulator parts, contact EXAIR at 1-800-903-9247 or techhelp@exair.com. Call (513) 671-3322 for outside the US and Canada.

CLEANING

If contaminants have clogged the Gen4 Super Ion Air Wipe, inspect the unit by disassembling. The Gen4 Super Ion Air Wipe consists of two component parts and between them is a shim that sets the gap the compressed air exhausts through. Inspect each part for dust or dirt contamination and a possible oil film in the area of the slotted nozzle. Clean each part and retighten bolts.

The best method to determine how well the Gen4 Super Ion Air Wipe is working is with the Model 7905 Static Meter. The static meter is easy to use and will accurately display the charge on a surface without touching it. To do this, simply measure the charge on the surface before ionizing (power supply and air off). Then, ionize the surface (power supply and air on). Measure the surface again. A "zero" volt reading indicates that the Gen4 Super Ion Air Wipe is working properly. If a charge is still present, this may indicate the need for cleaning.

Occasionally there is a buildup which occurs on the face of the Gen4 Super Ion Air Wipe as a result of vapors in the atmosphere. With the ionizers off and removed, clean this surface with solvent and a clean rag. To prevent contaminants from getting pushed back into the slot, perform this procedure with a small amount of compressed air passing through the Gen4 Super Ion Air Wipe. The emitter points can be cleaned with a small brush, **do not use any soaps or liquids**. Replacements are available for worn or damaged emitter points.

If you have any questions or problems, please contact:

YOUR INFO HERE:

Company Name
Telephone:
FAX:
E-mail:
Website:



EXAIR Gen4 Super Ion Air Wipe and Gen4 Power Supply are UL Component Recognized to U.S. and Canadian safety standards and meet the requirements of applicable European Directive(s).